



PLAYERUNKNOWN'S

BATTLEGROUNDS

4X4 AMERICAN PICKUP TRUCK
MAINTENANCE MANUAL

SAFETY PRECAUTIONS 安全注意事項

Please read all the instructions and familiarize yourself with the product and its controls before operation.

1. This product is not a toy. It is a high performance model car therefore it is important to familiarize yourself with the model, its manual, and its construction before assembly or operation. Adult supervision is necessary for children operating this model.
2. Always keep this instruction manual on hand during assembly and for operating reference.
3. Do not use a power screwdriver to install screws into plastic parts. A power screwdriver's high rotation speed can heat up the screw being installed which can result in some melting of the plastic parts or stripped threads.
4. For best performance, it is important to make sure all the moving parts can move freely without binding.
5. This product, its parts, and its assembly tools can be harmful to your health. Always exercise extreme caution when assembling and operating this product. Keep away from any high speed rotating parts during operation.

在您開始操作本產品之前，請詳閱本產品說明書。

1. 本產品為高性能模型產品非一般玩具，組裝與操作過程皆需由成人陪同。
請詳讀此本使用說明書，避免因組裝錯誤與操作不當造成損壞。
2. 請妥善保管此說明書，對於後續維修、操控說明將可提供您協助。
3. 請勿使用電動工具旋緊自攻螺絲於塑膠零件上，可能導致塑膠零件融化或滑牙。
4. 請檢視所有活動部位零件是否不受干涉、可靈活作動，以達車輛最佳性能。
5. 此項商品具有相當之危險性，於組裝、操控上的不熟悉都可能造成自身或他人的傷害。

INDEX 索引

STEP 1	CHASSIS 車體	P2	STEP 18	SIDE GUARD 側板	P11
STEP 2	FRONT/REAR DIFFERENTIAL 前 / 後差速器	P3	STEP 19	FRONT BUMPER 前防撞板	P12
STEP 3	FRONT AXLE 前傳動組	P4	STEP 20	REAR BUMPER 後防撞板	P12
STEP 4	FRONT STEERING SET 前轉向組	P4	STEP 21	FRONT/REAR BODY POSTS 前 / 後車殼支柱	P13
STEP 5	REAR HUB SET 後輪座組	P5	STEP 22	WHEELS & TIRES 輪框與輪胎	P13
STEP 6	SHOCK ASSEMBLY 避震器組	P5	STEP 23	LED LIGHT BAR SET 車殼燈架組	P14
STEP 7	FRONT ADJUSTABLE LINKS 前可調連桿組	P6	STEP 24	BODY/REAR CABIN 車殼 / 頂棚	P15
STEP 8	FRONT SUSPENSION 前懸吊組	P6	STEP 25	BODY 車殼	P16
STEP 9	REAR ADJUSTABLE LINKS 後可調連桿組	P7			
STEP 10	REAR SUSPENSION 後懸吊組	P7	WHEEL AND TIRE PREPARATION 輪框與輪胎拆卸	P17	
STEP 11	CENTER GEAR 中央齒輪	P8	BATTERY CHARGING 電池充電指南	P17	
STEP 12	CENTER DRIVE SHAFT 中央傳動軸	P8	TRANSMITTER 2.4Hz SYSTEM 2.4Hz 遙控器說明	P18	
STEP 13	CENTER GEAR CASE 中央齒輪箱	P9	BATTERY INSTALLATION 安裝電池	P19	
STEP 14	MOTOR 馬達組	P9	RADIO OPERATION 遙控器操作	P19	
STEP 15	BATTERY PLATE 電池板	P10	OPERATING RADIO STEERING FUNCTION 遙控器設定轉向	P20	
STEP 16	SERVO SET 伺服機組	P10	DRIVING BASIC 操控基本動作	P20	
STEP 17	STEERING TURNBUCKLE 轉向拉桿	P11	PARTS LIST 零件表	P21.P22	

TOOLS REQUIRED FOR ASSEMBLY 組裝維修工具



Hex Driver Tool Set (1.5/2.0/2.5mm)
六角板手組

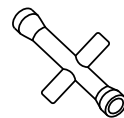

Xwrench
十字套筒

SYMBOL REFERENCE KEY 說明書符號說明



Build right and left assembly
組裝左和右配件



Build front and rear assembly
組裝前和後配件



Assemble the parts two times
組裝相同配件兩次



Assemble the parts four times
組裝相同配件四次



TT Media Technology, Inc.

1F., NO.540, SEC. 1, MINSHENG N. RD.,
GUISHAN DIST., TAOYUAN CITY 333, TAIWAN



STEP 1

CHASSIS 車體

BHCS M2.5x8mm x16

FHCS M2.5x10mm x2

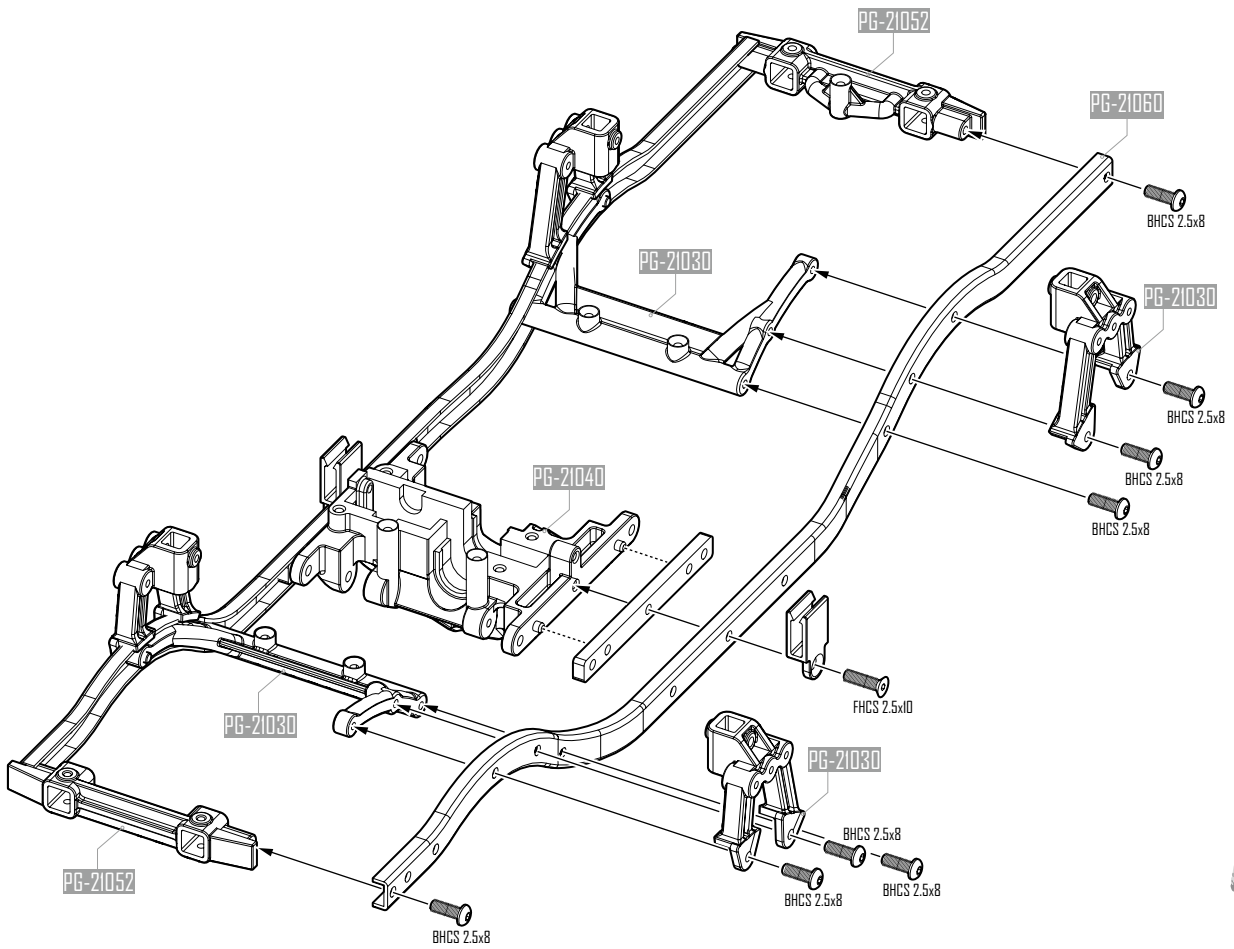



STEP 2

FRONT/REAR DIFFERENTIAL 前/後差速器

BHCS M2x10mm x8

BHCS M3x20mm x8

FHCS M3x6mm x2

BEARINGS 5x10x4mm x4

BEARINGS 10x15x4mm x4

X2

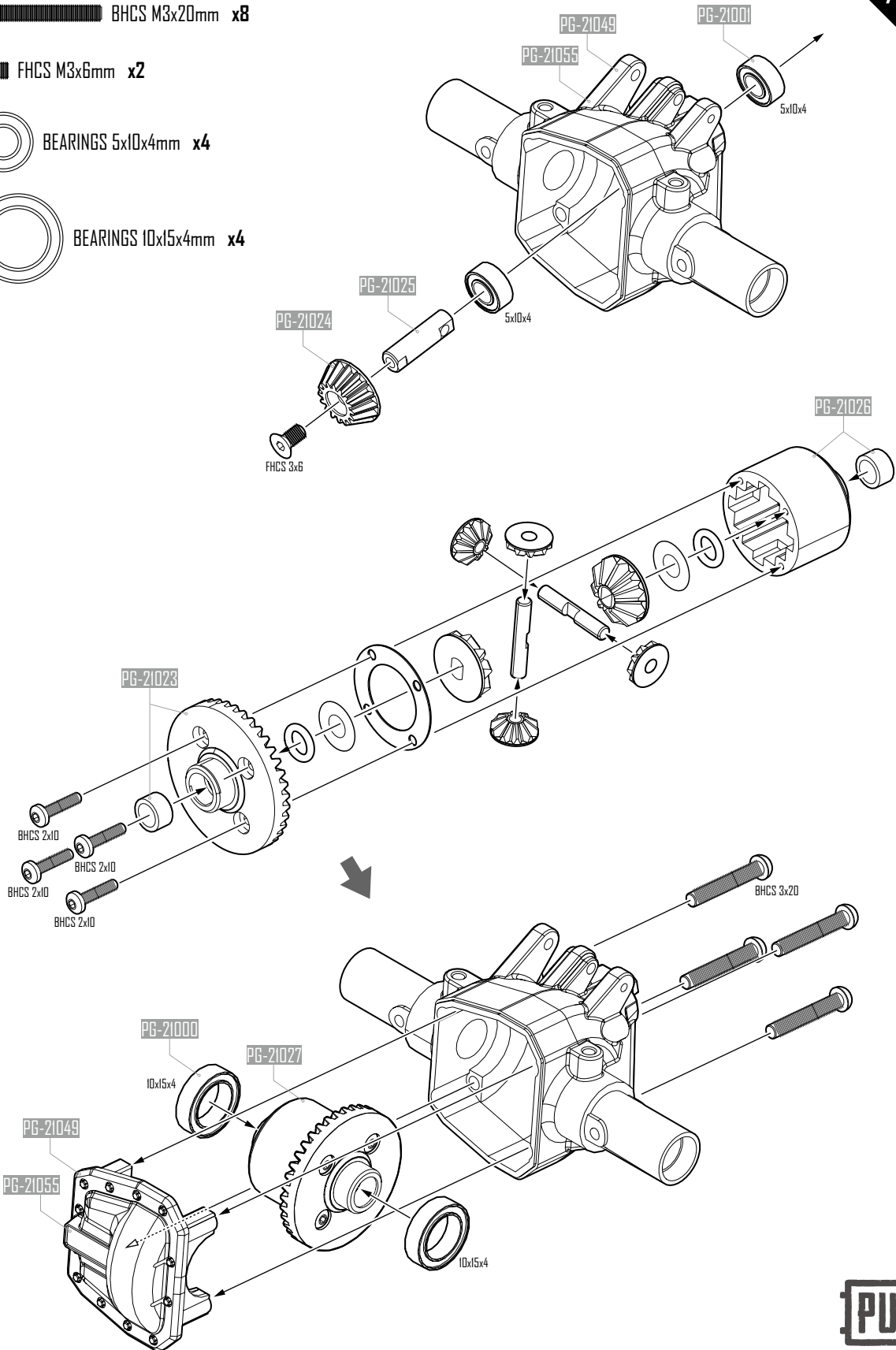



STEP 3

FRONT AXLE 前傳動組

BHCS M3x4mm x4

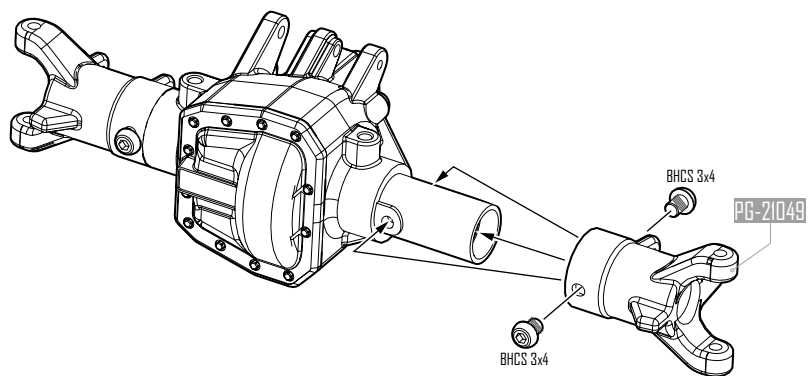

STEP 4

FRONT STEERING SET 前轉向組

C-HUB SCREW M3x11.6mm x4

BEARINGS 5x10x4mm x4

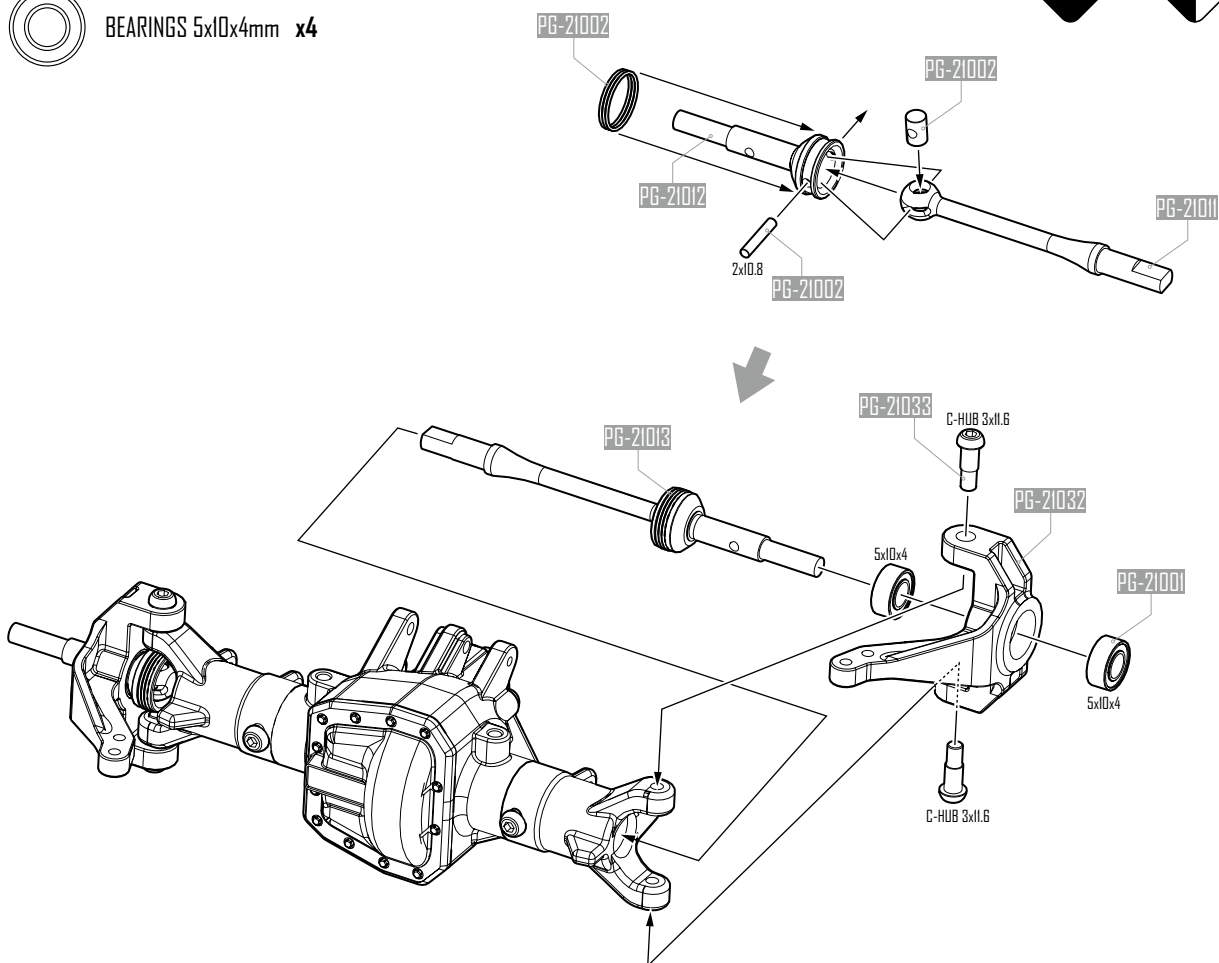



STEP 5 REAR HUB SET 後輪座組

BHCS M3x4mm x4

BEARINGS 5x10x4mm x2

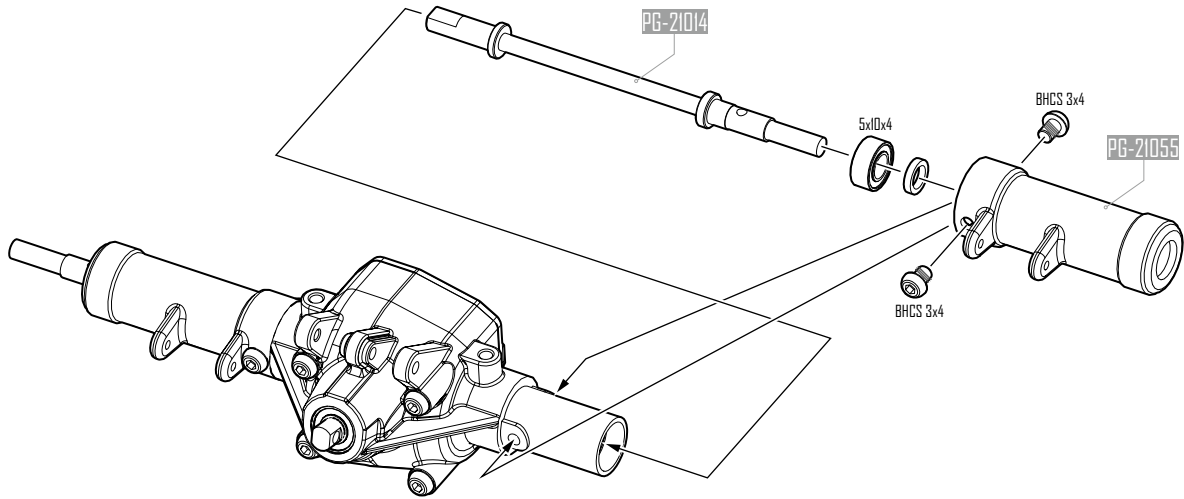

STEP 6 SHOCK ASSEMBLY 避震器組

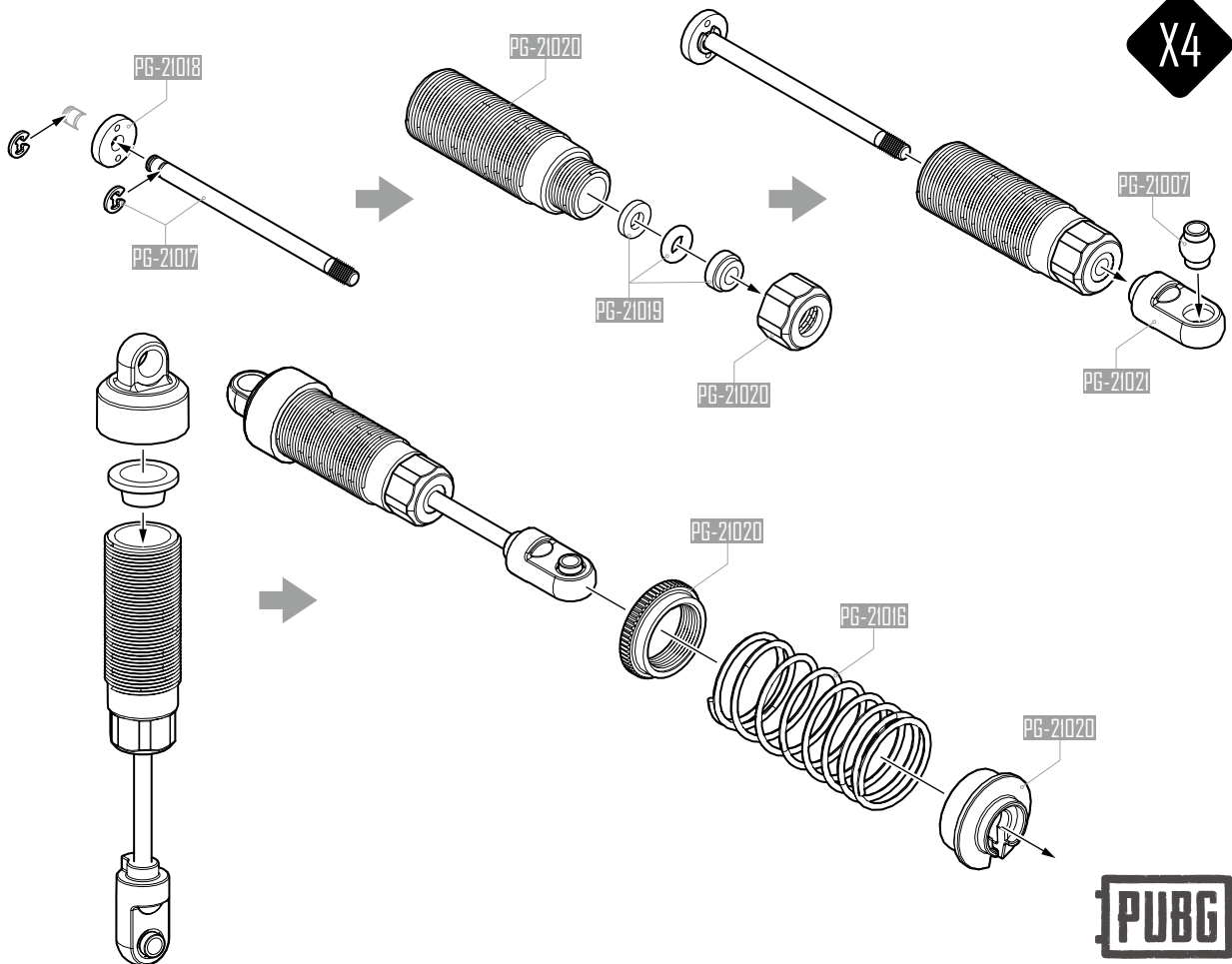





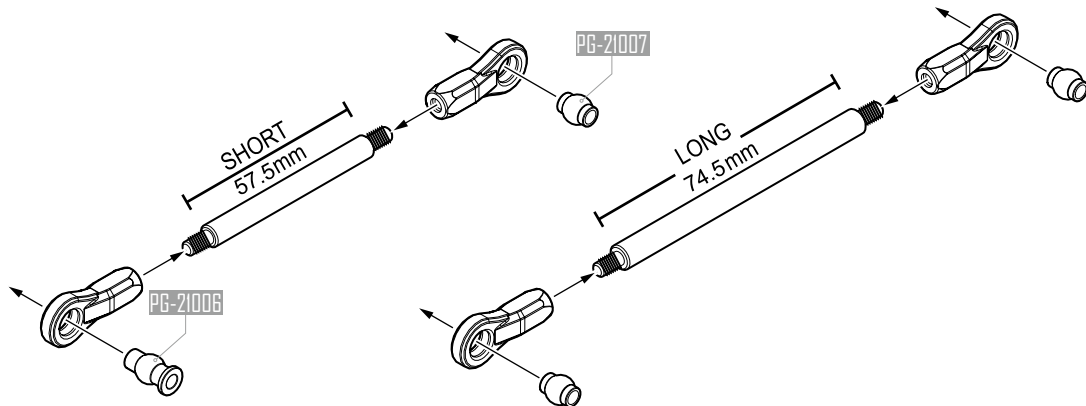

STEP 7

FRONT ADJUSTABLE LINKS 前可調連桿組



STEP 8

FRONT SUSPENSION 前懸吊組

-  BHCS M2.5x10mm x2
-  BHCS M2.5x4mm x4
-  BHCS M2.5x20mm x2
-  BHCS M2.5x25mm x1

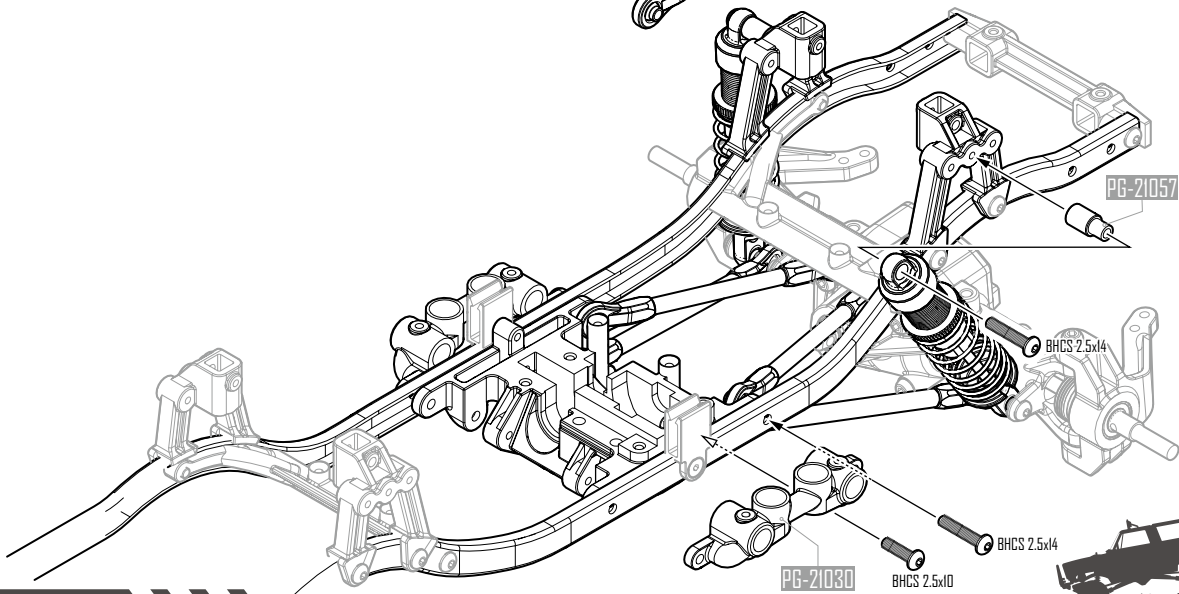
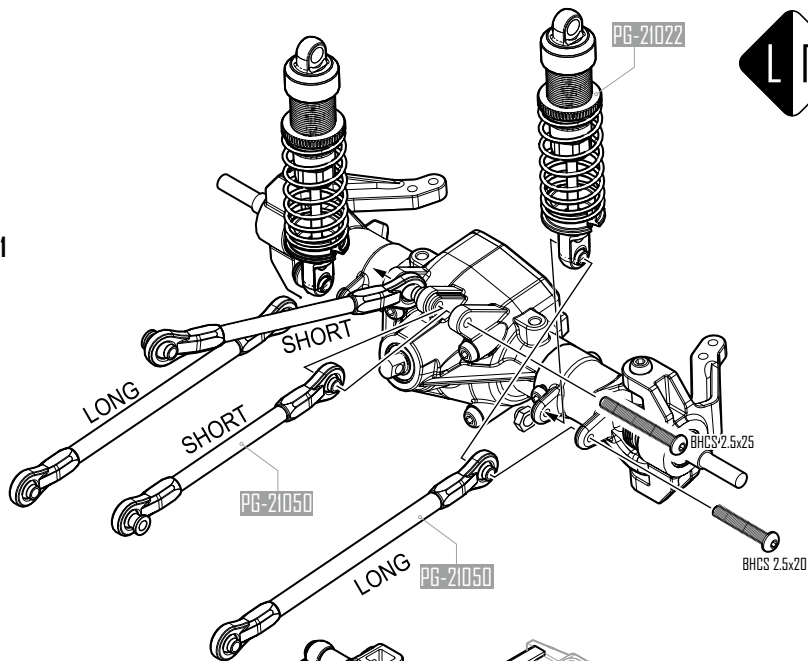



STEP 9

REAR ADJUSTABLE LINKS 後可調連桿組

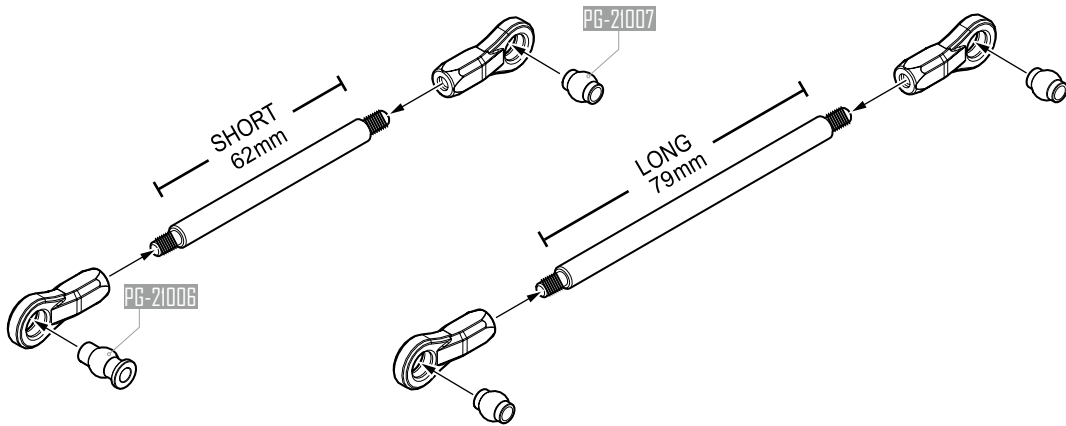





X2



STEP 10

REAR SUSPENSION 後懸吊組

-  BHCS M2.5x10mm x2
-  BHCS M2.5x4mm x4
-  BHCS M2.5x20mm x2
-  BHCS M2.5x25mm x1

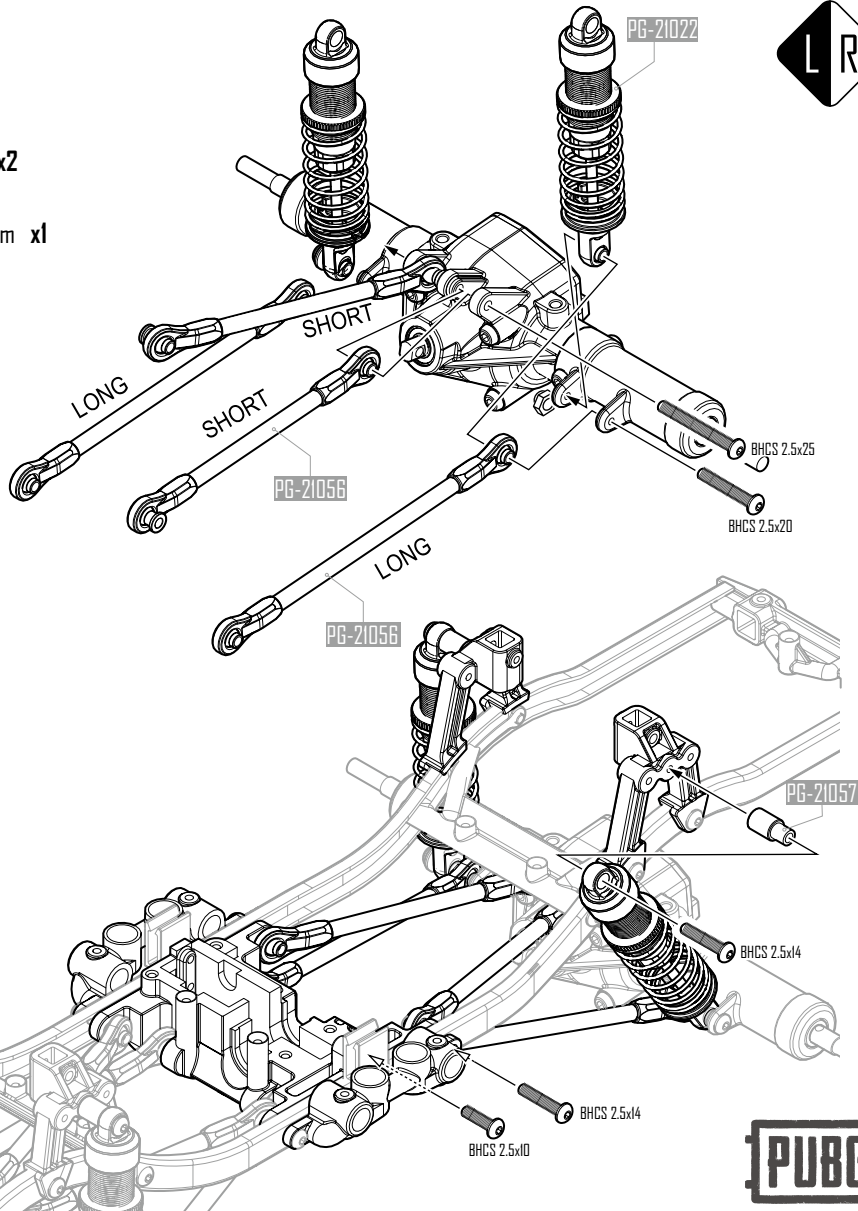

LR





STEP 11

CENTER GEAR 中央齒輪

PIN M2x7.8mm x1

BEARINGS 5x10x4mm x2

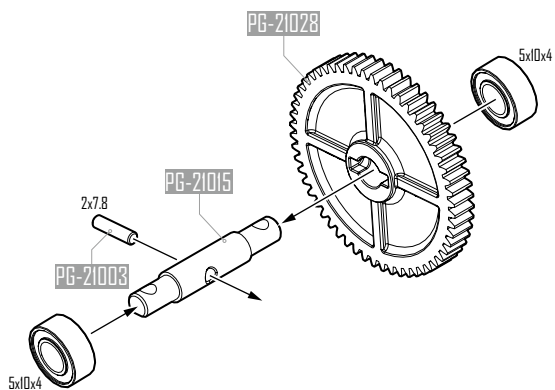

STEP 12

CENTER DRIVE SHAFT 中央傳動軸

LONG SCREW PIN x4

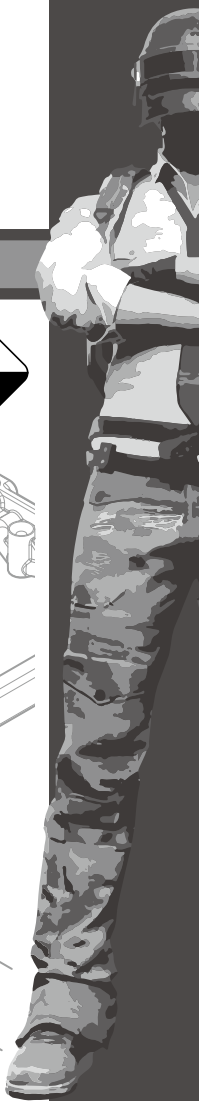
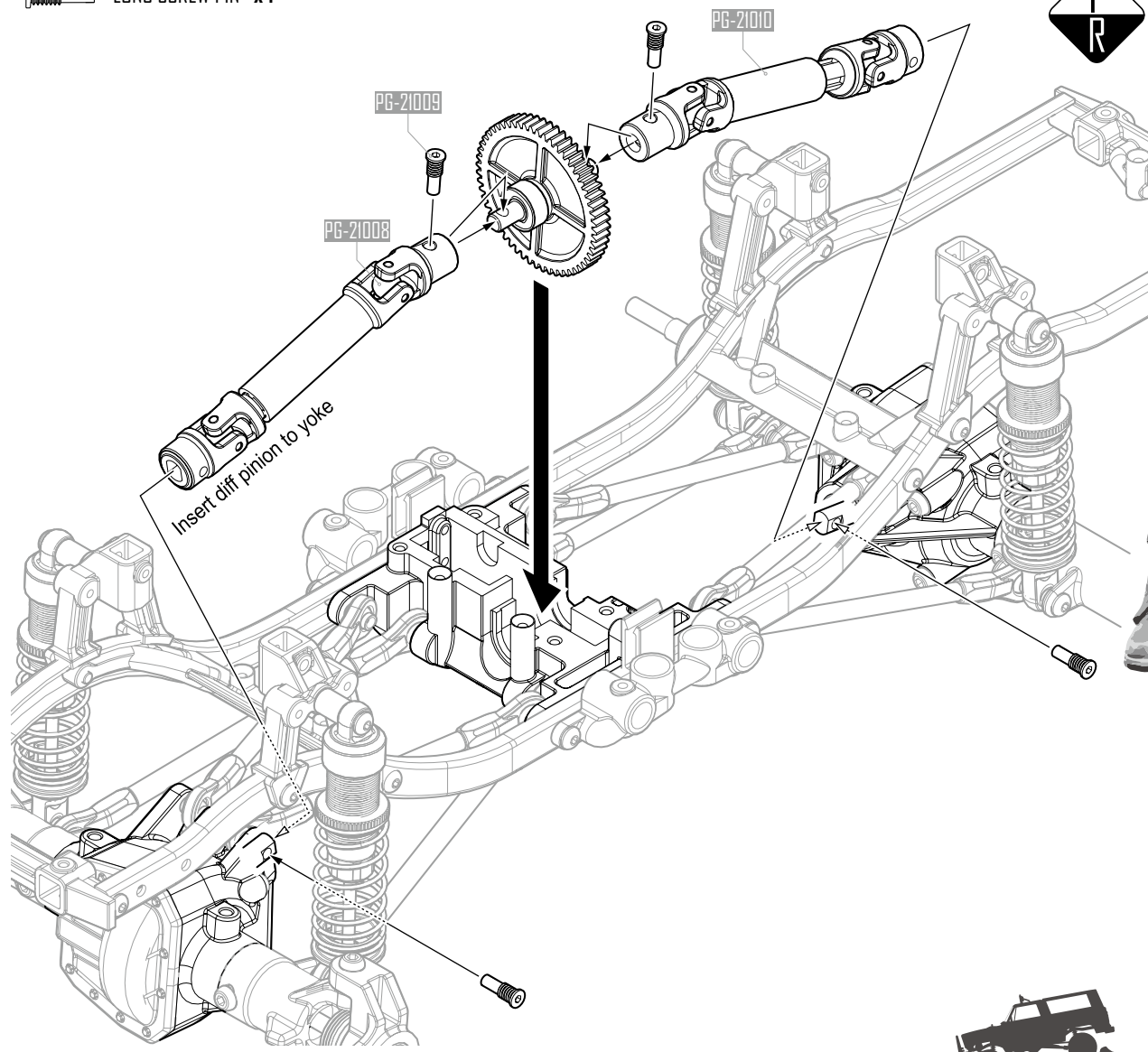



STEP 13 CENTER GEAR CASE 中央齒輪箱

BHCS M3x8mm x2

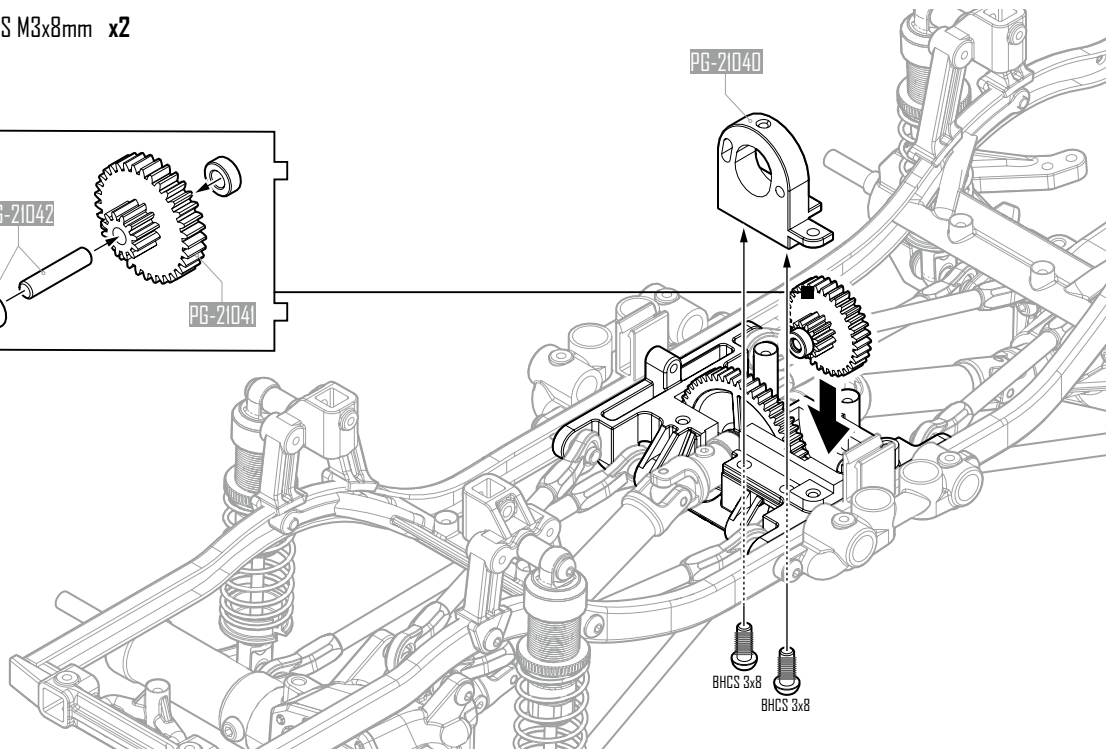
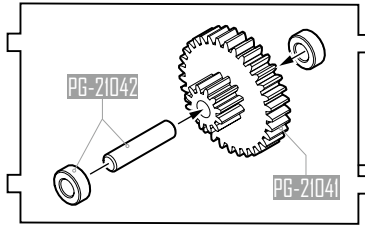

STEP 14 MOTOR 馬達組

BHCS M2.5x10mm x7

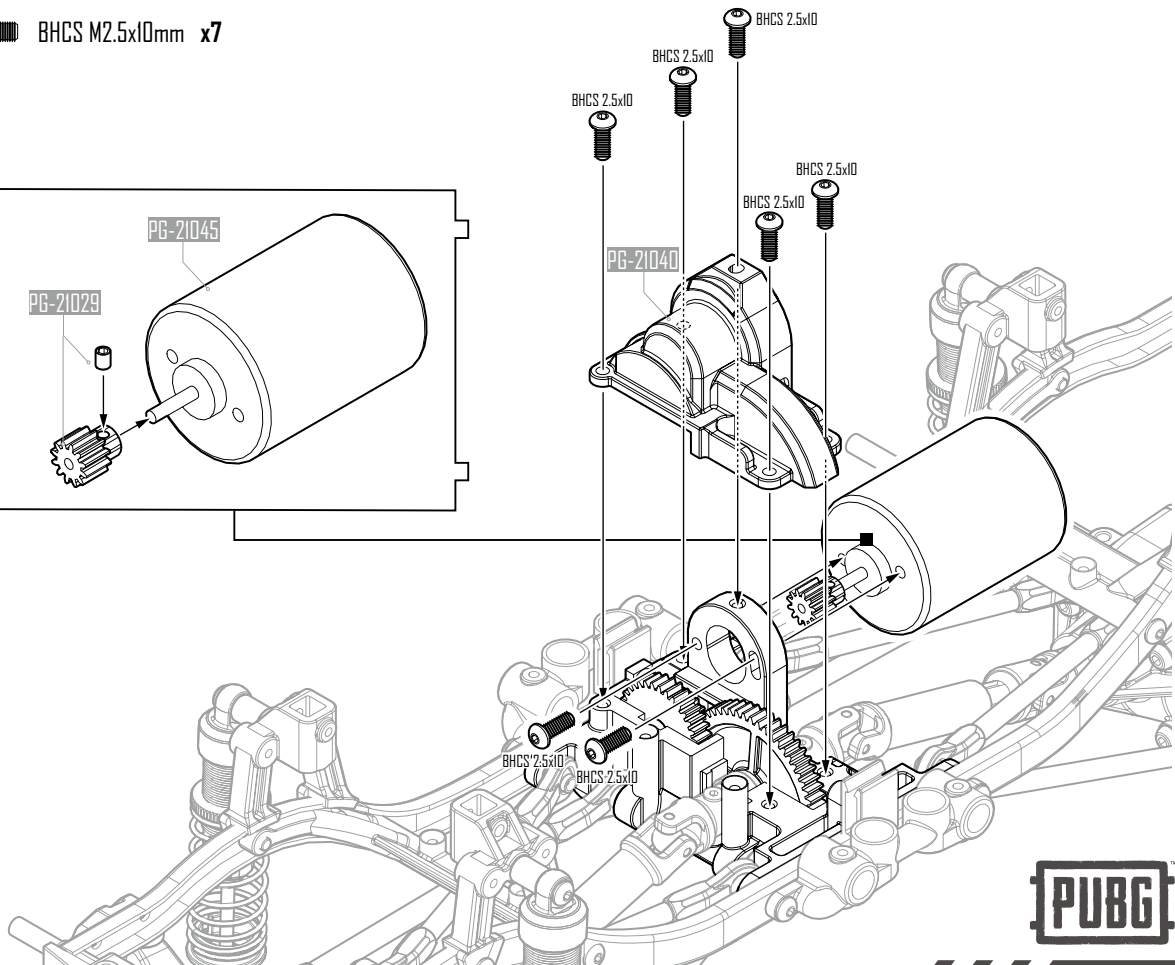
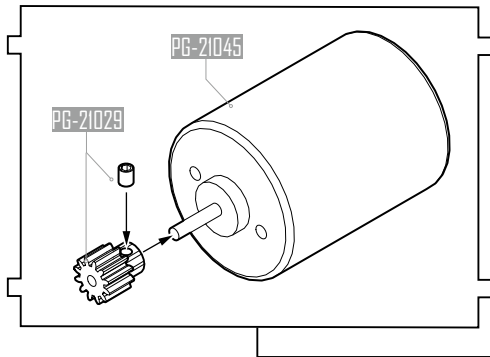



STEP 15 BATTERY PLATE 電池板

FHCS M2.5x12mm x2

BHCS M2.5x4mm x2

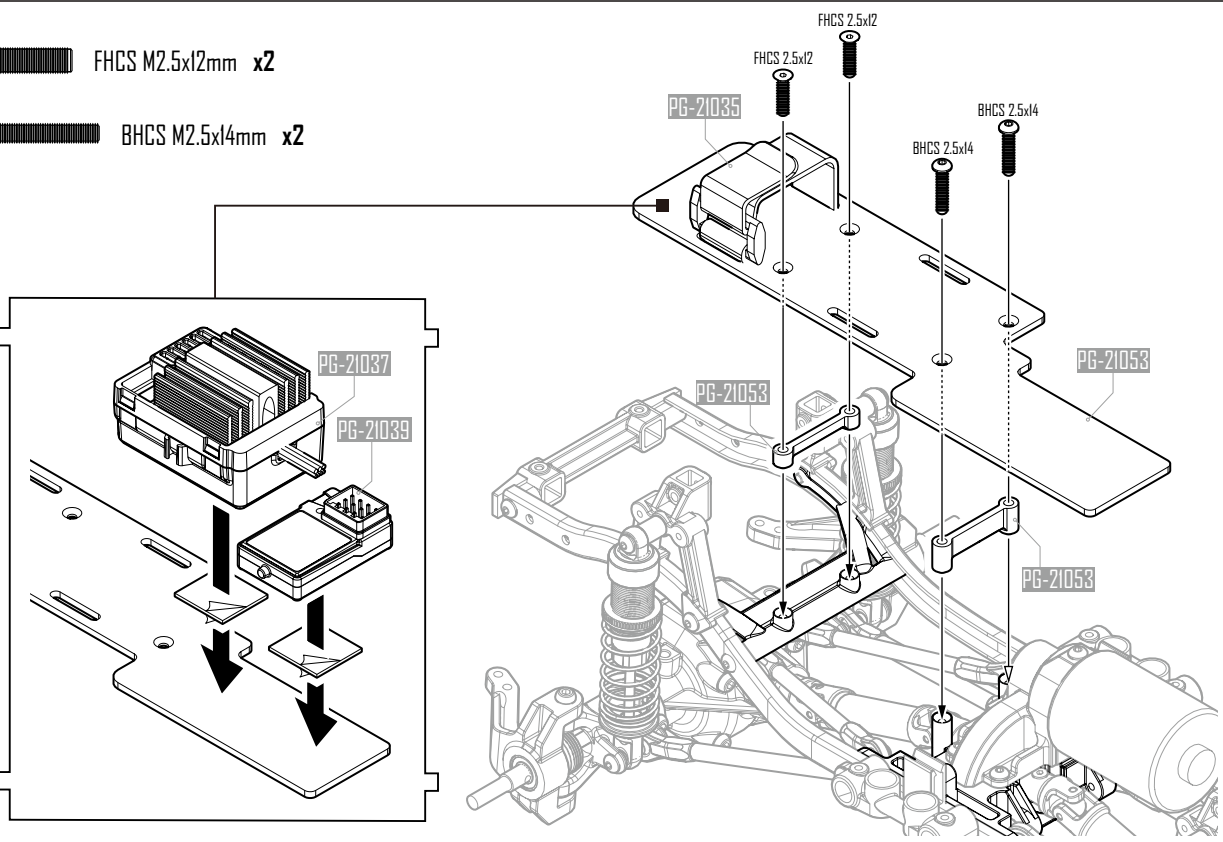

STEP 16 SERVO SET 伺服機組

BHCS M2.5x10mm x4

BHCS M3x10mm x5

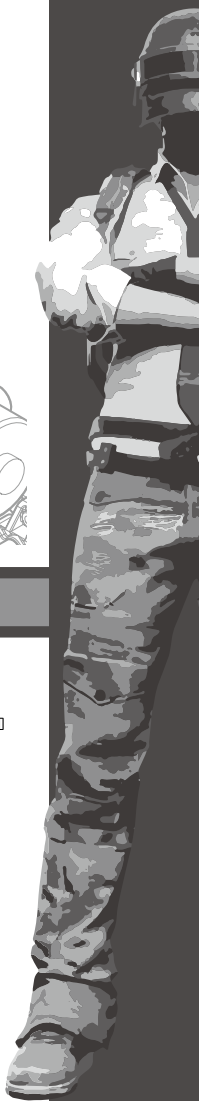
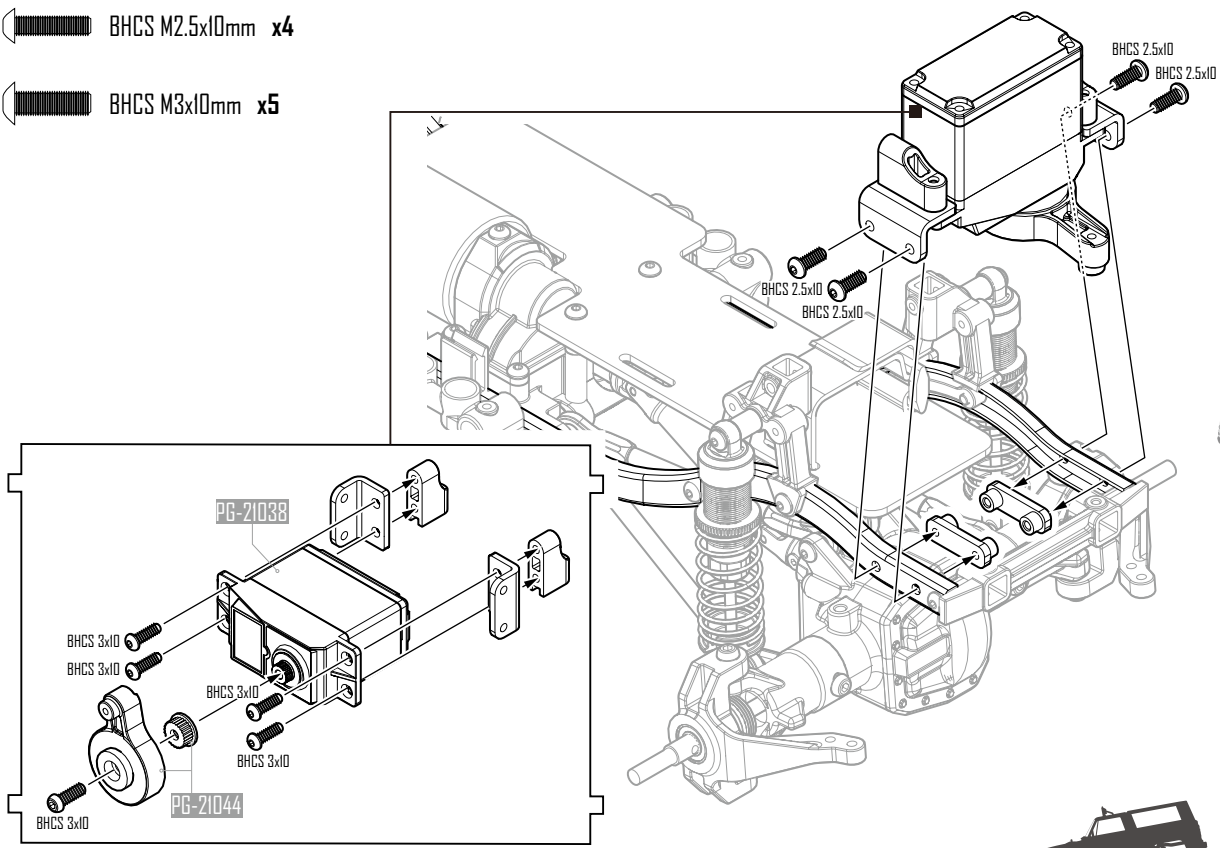



STEP 17

STEERING TURNBUCKLE 轉向拉桿

BHCS M2.5x10mm x2

BHCS M2.5x4mm x1

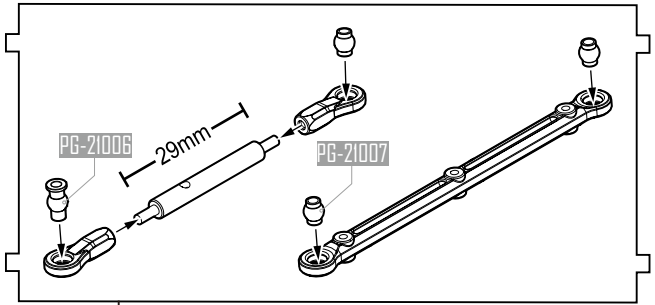
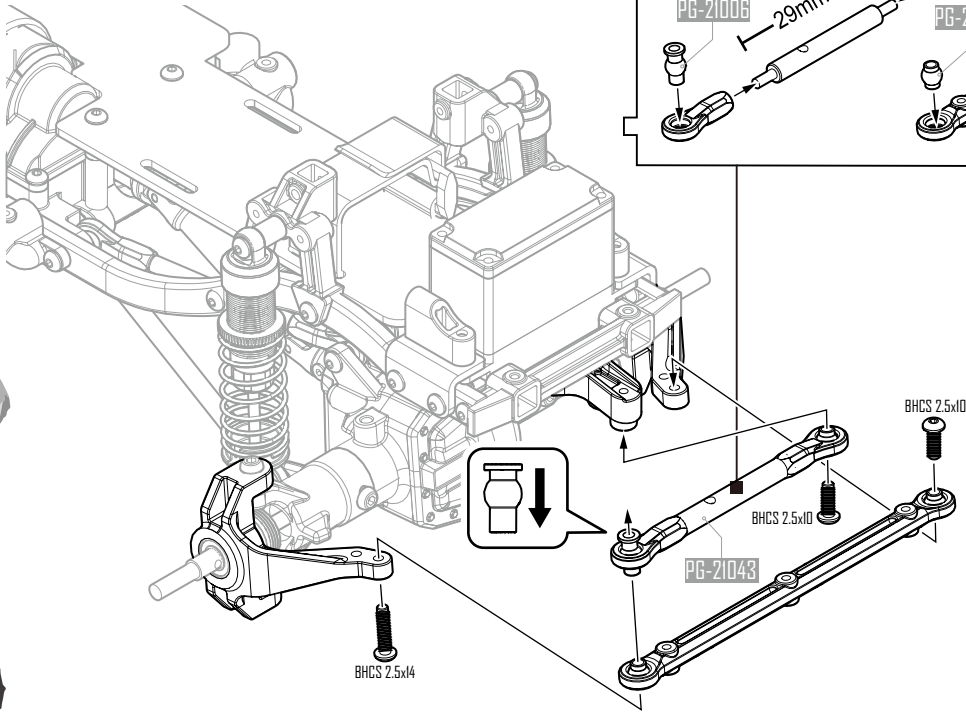

STEP 18

SIDE GUARD 側板

BHCS M2.5x8mm x4

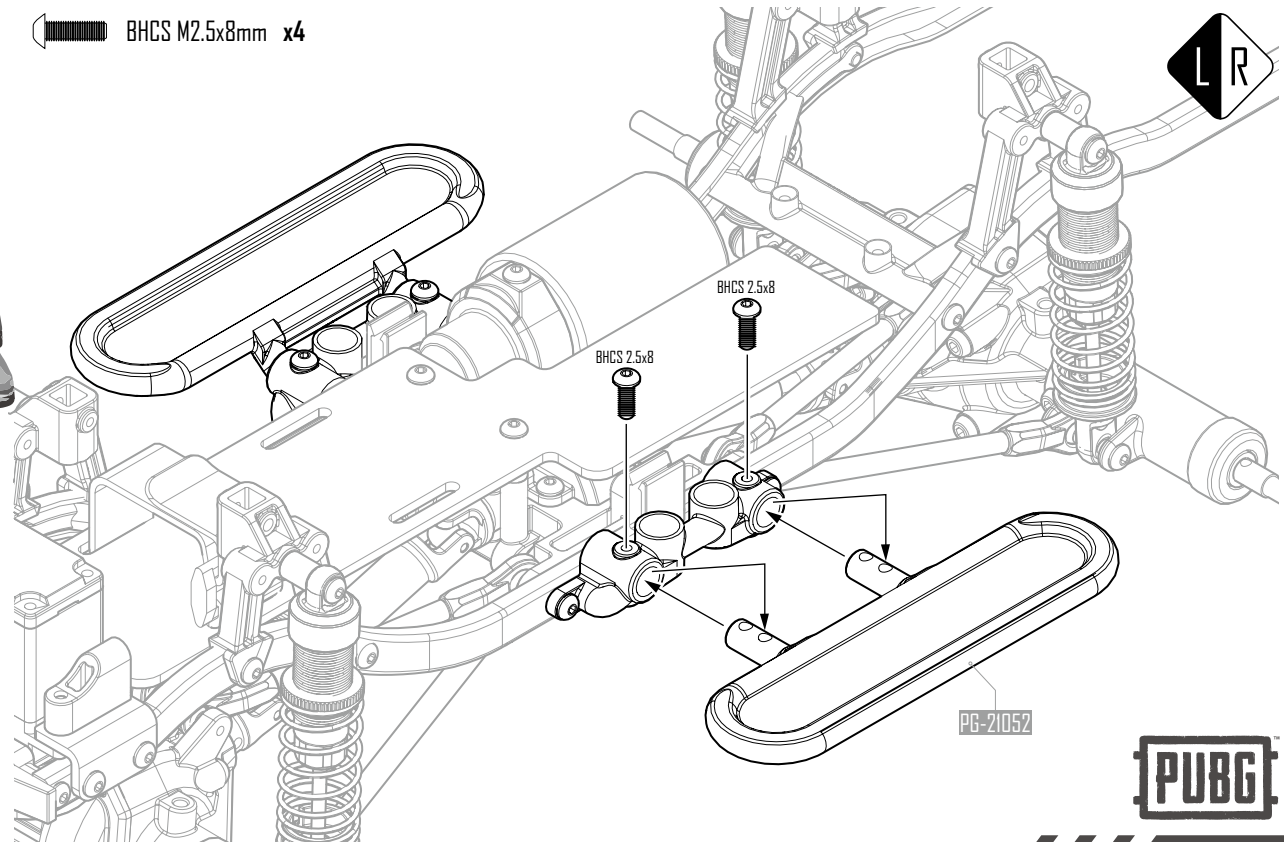



STEP 19

FRONT BUMPER 前防撞板

BHCS M2.5x8mm x2

BHCS M2.5x16mm x2

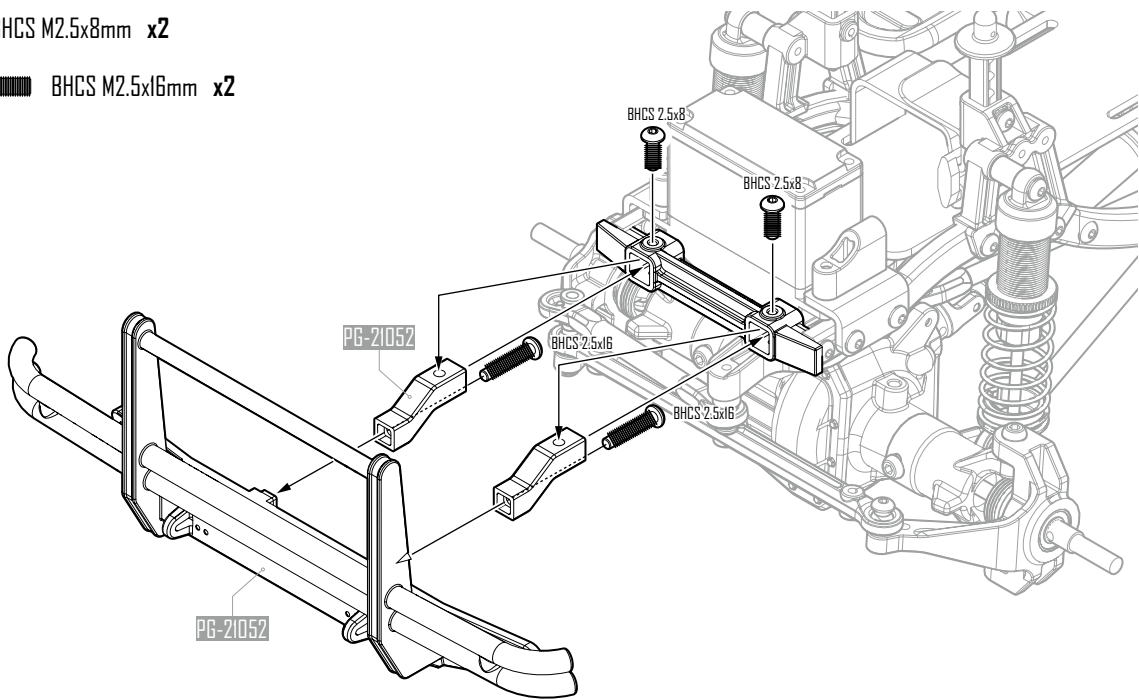

STEP 20

REAR BUMPER 後防撞板

BHCS M2.5x8mm x2

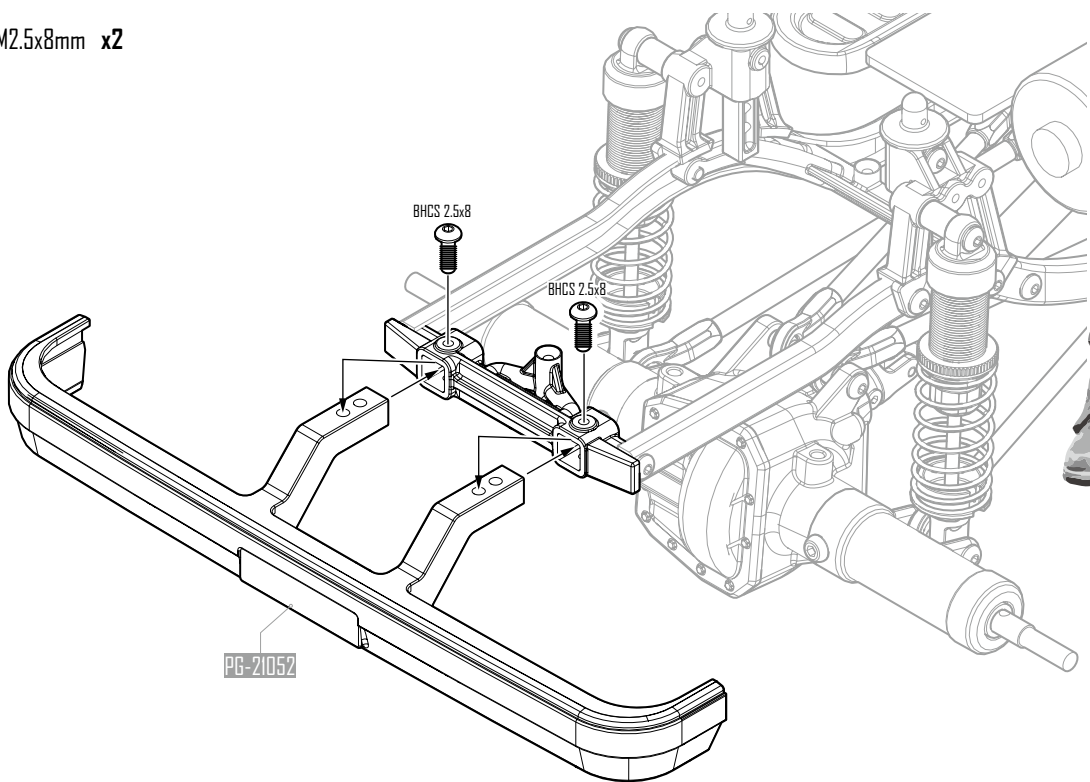



STEP 21

FRONT/REAR BODY POSTS 前/後車殼柱

BHCS M2.5x10mm x4

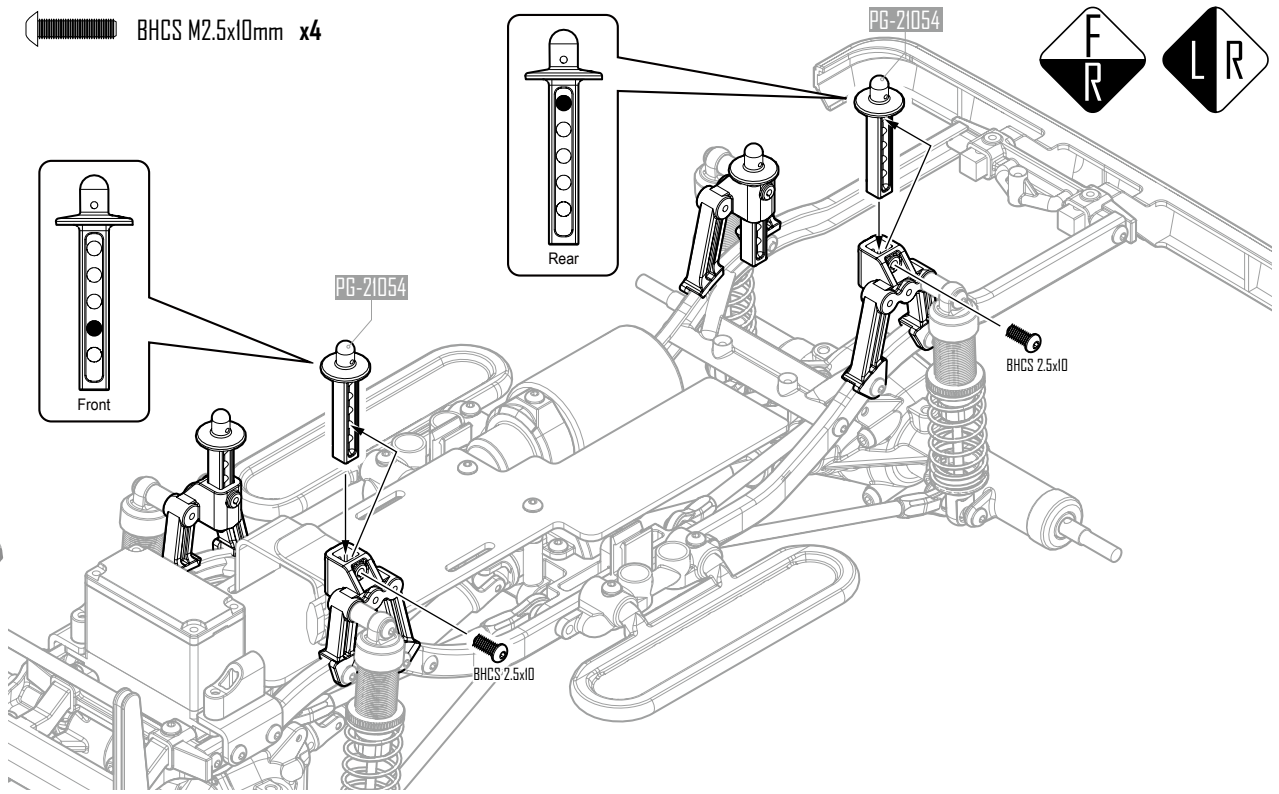
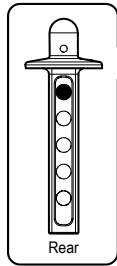
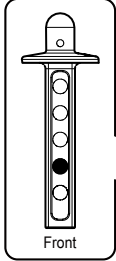

STEP 22

WHEELS & TIRES 輪框與輪胎

M4 LOCK NUT x4

X4

LR

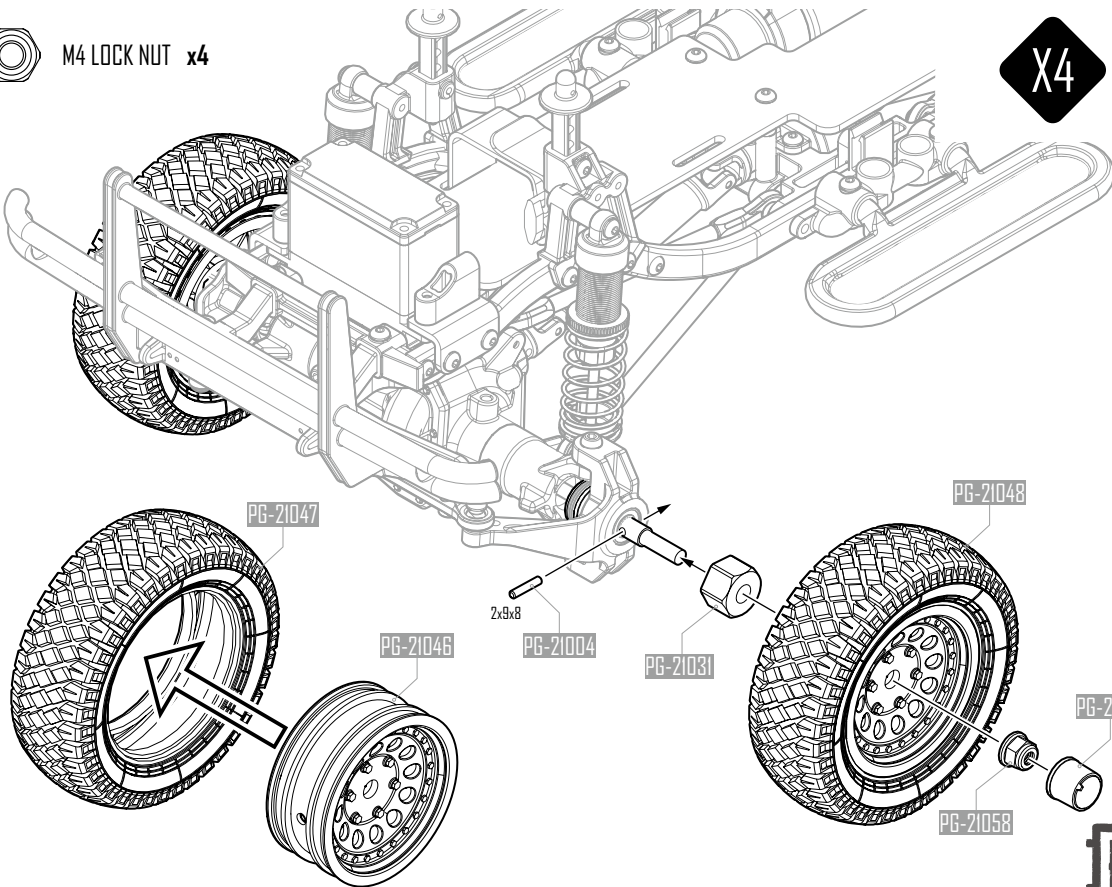



STEP 23

LED LIGHT BAR SET 車殼燈架組

- ☐ SHCS M2x4mm x4
- ☐ SHCS M2x6mm x8
- ☐ SHCS M2x8mm x4
- ▨ BHCS M2.5x6mm x2
- ▨ BHCS M3x8mm x2

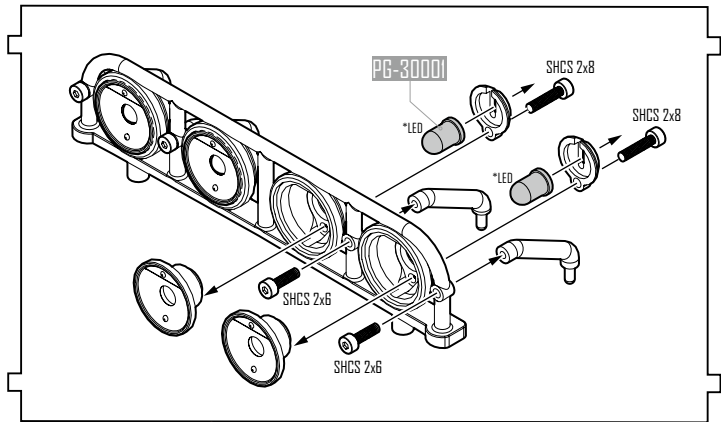

OPTION



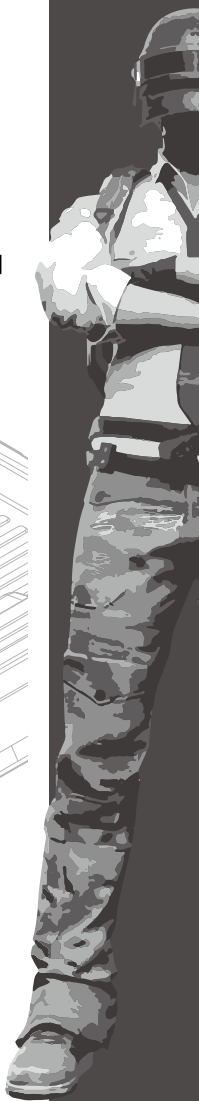
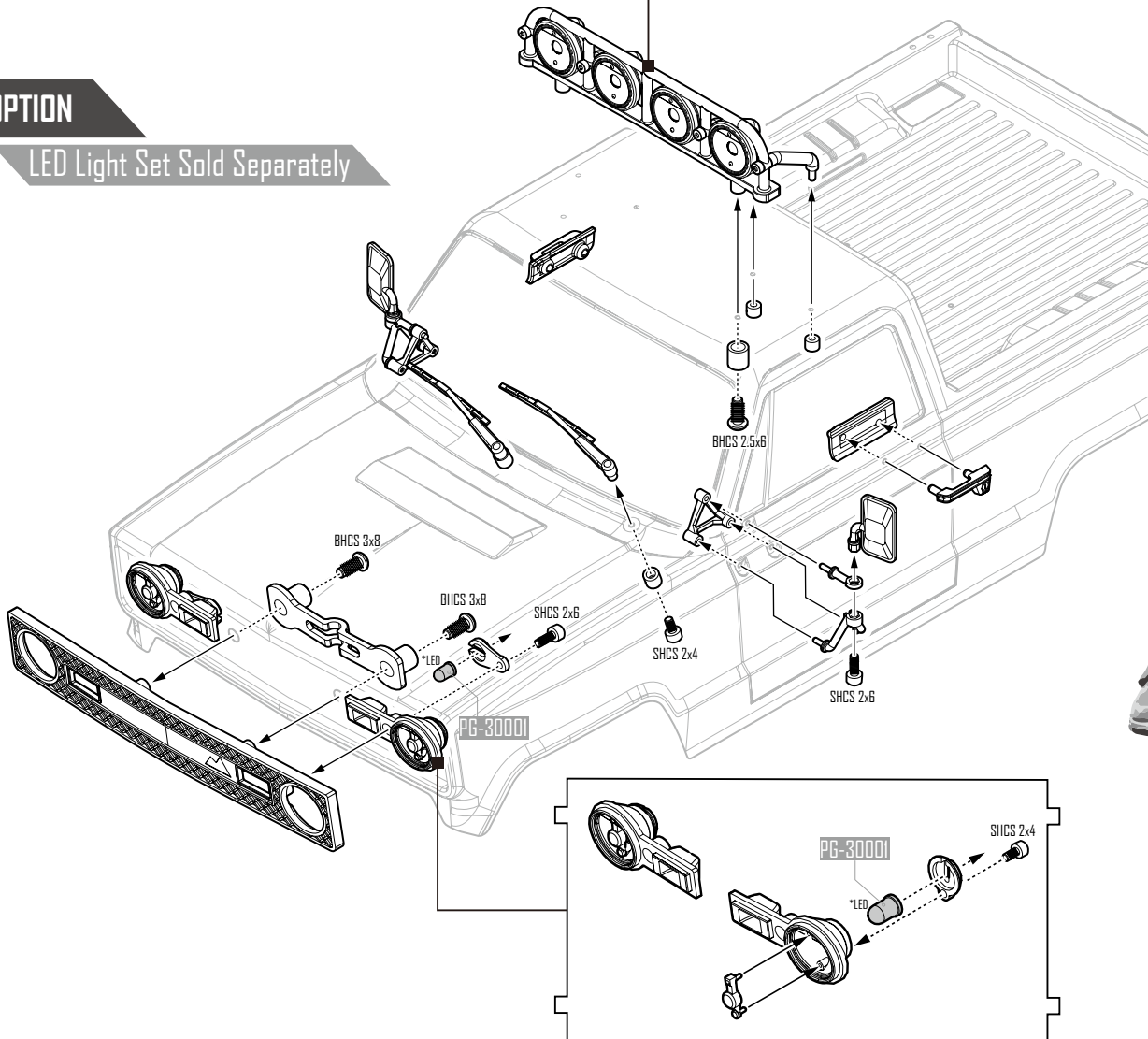

LED Light Set Sold Separately





STEP 24

BODY/REAR CABIN 車殼/頂棚

-  SHCS M2x6mm x4
-  BHCS M2x6mm x6
-  BHCS M2.5x6mm x4
-  BHCS M3x8mm x2

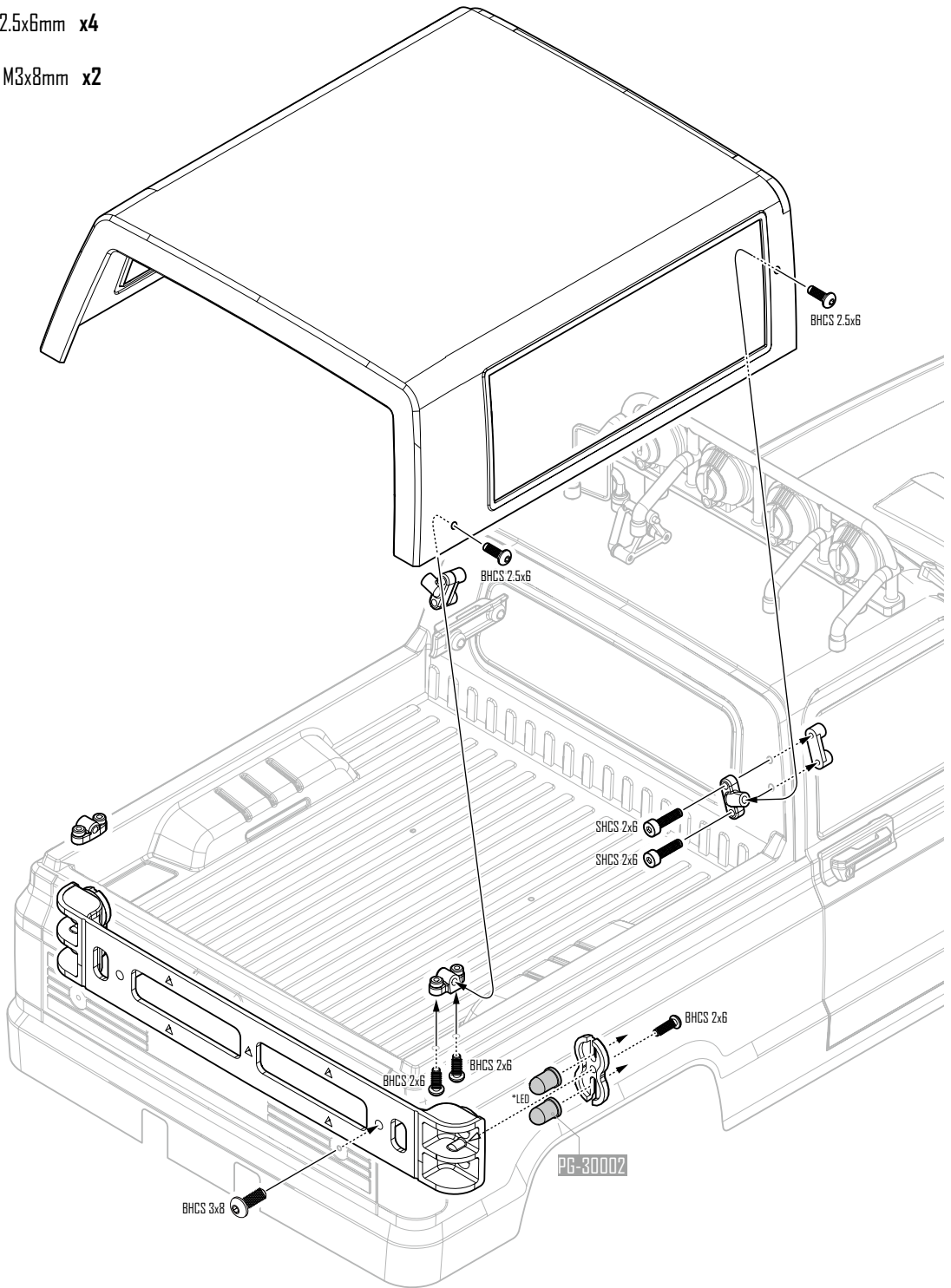

OPTION

LED Light Set Sold Separately





STEP 25

BODY 車殼

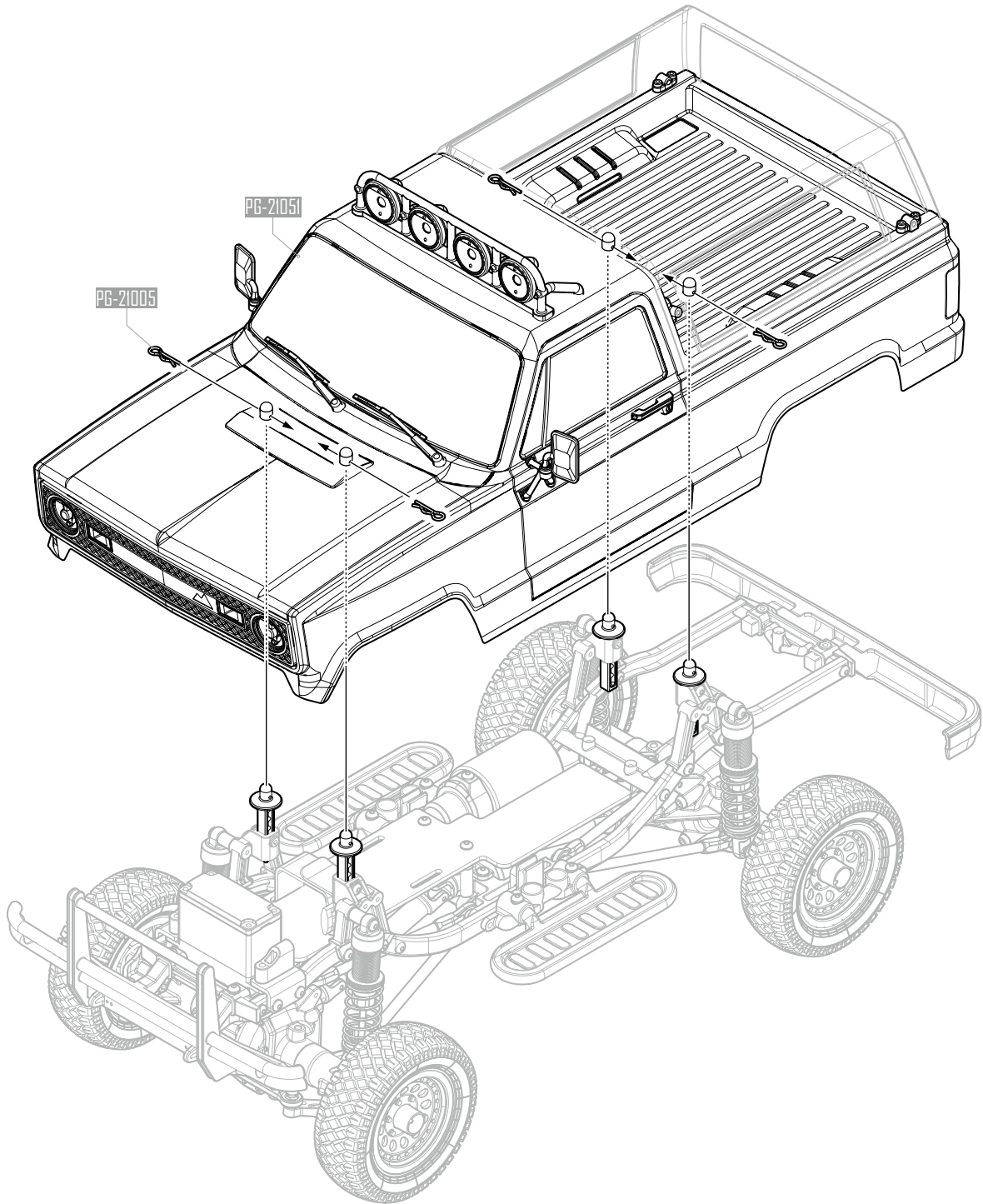



WHEEL AND TIRE PREPARATION 輪框與輪胎拆卸



[1] Remove the wheel cap anticlockwise.
以逆時針旋扭將輪框蓋取下。



[2] Remove wheel lock nut using the Xwrench and detach wheels.
使用內附之六角螺帽套筒扳手將輪軸上六角固定螺帽取下。

⚠ Make Sure The Axle Nuts Are Tight Before Each Run

Before operating your vehicle, take a moment to make sure the axle nuts are tight, as they may have loosened during shipping. The correct size axle-nut wrench is supplied with the truck. Check the tightness of the axle nuts before each run. Please continue to check tightness prior to operating vehicle each time.

⚠ 輪胎鎖附步驟加註注意事項

在操作之前請先確認輪胎之固定六角螺帽是被鎖緊的。如未鎖緊，可使用隨車所附的螺帽套筒扳手將螺帽鎖緊。每趟跑完或是再次出發前請務必檢查固定螺帽是否鬆脫？此車之高轉速與高扭力很可能於每一次的操作時使螺帽漸漸地鬆脫。



BATTERY CHARGING 電池充電指南

Battery Charging Steps and Safety:

Remove the battery from the vehicle before charging.

Place battery on a fire resistant surface.

Avoid any contact with water or other liquids.

從車台上將電池取出後，請將電池擺放在防火墊上，並且避免接觸到任何液體。

ALWAYS use a compatible charger for charging your batteries.

充電時請選擇適當的USB變壓器。

⚠ Never leave the battery unattended while charging. Always disconnect the charger from the power source when finished charging.
充電時如中途離開，請務必拔除充電線。

⚠ Always disconnect the battery when you are finished driving the vehicle.
在不遊玩車台的情況下，請拔除電池的電源線。



USB Charger



TRANSMITTER 2.4GHz SYSTEM 2.4Hz遙控器說明

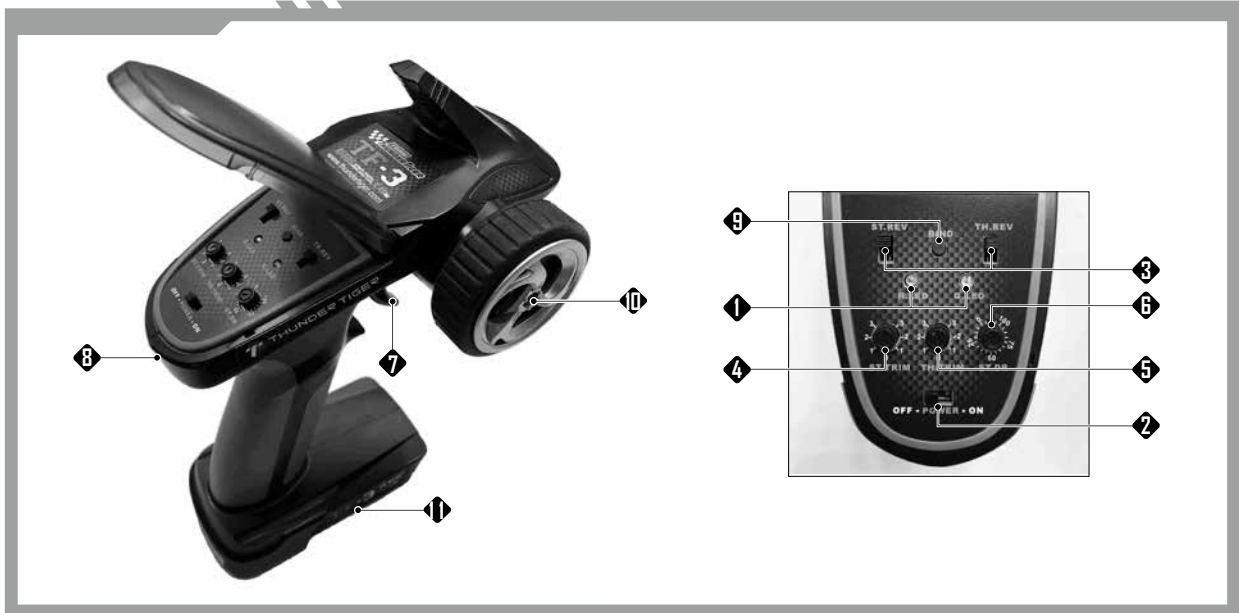

TRANSMITTER CONTROLS 發射機各部功能簡介

- 1** Battery Level Indicator
發射機電源顯示燈

Green / Red LEDs indicate the battery voltage. If the Red LED flashes, please replace the batteries.
兩顆LED設計顯示發射機電池殘量，若紅色LED燈閃爍時，請更換發射機電池。
- 2** Power Switch
電源開關

Slide to turn the transmitter on or off.
發射機電源開關。
- 3** Servo reversing switches
正逆轉設定裝置

To reverse the servo's rotation direction at the flip of the switch.
The reversing switches are recessed into the transmitter to prevent accidental operation.
依實際使用，控制伺服機作動方向。
- 4** Steering Trim
轉向微調鈕

Adjusts the steering in small increments or decrements to run the model straight.
利用此旋鈕，調整設定轉向正確中立點位置。
- 5** Throttle Trim
油門微調鈕

Adjusts the throttle in small increments or decrements to shift the neutral position.
利用此旋鈕，調整設定油門正確中立點位置。
- 6** Steering D/R (Dual Rates)
轉向大小動調整鈕

Turn this knob left or right to adjust the amount of the steering dual rate.
Right to increase dual rate amount and left to decrease the amount.
調整轉向伺服機的行程量。
- 7** Throttle Trigger
油門控制板機

Pull or push to control the movement of the model.
控制車輛前進或後退的裝置。
- 8** External Charging Jack
充電孔

For rechargeable NiCd/NiHM battery pack on the transmitter only.
使用充電式電池時，可利用此充電孔，進行充電工作。
- 9** 2.4GHz Binding
校頻配對設定鈕

The Binding button is located on the top of the 2.4GHz transmitter.
2.4Hz 之 BINDING SW 校頻配對設定鈕，為配對發射接收頻率之用。
- 10** Steering Wheel
轉向舵輪

Control the steering of the model.
控制車輛轉向裝置。
- 11** Battery Cover
電池蓋

Slide cover to install or remove batteries.
推移電池護蓋即可取出電池進行更換。



BATTERY INSTALLATION 電池安裝



[1]
Install 4pcs alkaline or rechargeable AA-size batteries into transmitter.
安裝 4 顆三號鹼性電池或充電電池於發射機內。



[2]
Put battery onto battery tray.
安裝電池於電池盒中。



[3]
Connect battery cable with (ESC) Electronic Speed Controller cable.
將電池線連接速控器電源線。

⚠ Disconnect Batteries After Use

Always disconnect the batteries from the Speed Controller when you are finished using your vehicle. The switch on the Speed Controller only shuts off power to the receiver and servos. The Speed Controller continues to draw power as long as it is plugged in and may overdischarge your batteries if they are left connected to the Speed Controller.

⚠ 操作完畢注意事項

請務必於每次操作完畢後解除電子速控器與電池的連結狀態。電子速控器電源開關僅只關掉接收機與伺服機的電源供應。電池內部電流消耗會因為電源線未拔離而持續且可能會因此而過度放電而導致無法預期的危險。



RADIO OPERATION 遙控器操作

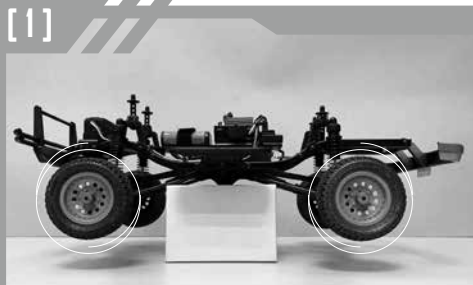

⚠ WARNING: The electronic system is powerful. For safety, please always keep the wheels away from the ground when you are preparing to switch on the car.

⚠ 注意：本系統功率十分強勁！基於安全因素，建議請在車輪懸空的裝態下開啟系統電源，避免非預期性的暴衝。



[2]
When turning radio system on. Turn the transmitter on first, then turn on the ESC.
為避免車子失控暴衝，先開啟發射機電源。

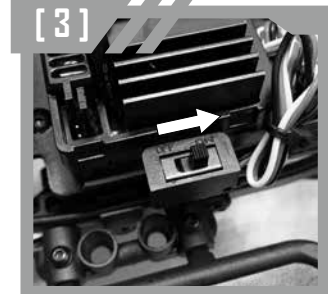

[3]
When turning the radio system off. Turn the ESC off first, then turn off the transmitter.
接著開啟速控器電源。電源的關閉則是相反的順序，先關速控器電源，再關發射機電源。



OPERATING RADIO STEERING FUNCTION 遙控器設定 轉向

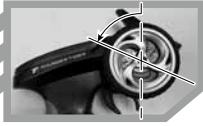
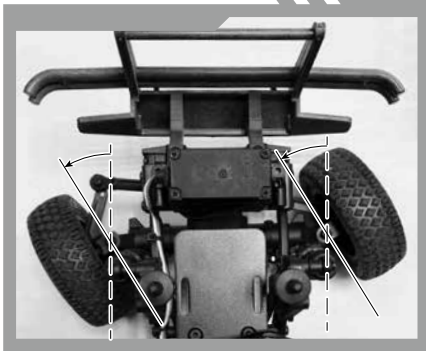

Check the radio steering functions. With the radio transmitter and receiver on, turn the steering wheel to the left. The front tires /wheels should turn left accordingly. If not, flip the steering servo reverse switch.

確認轉向功能。打開發射機及接收機電源，方向轉左邊時，輪胎將朝向左邊，若方向不一致，請調整方向的正逆轉開關。

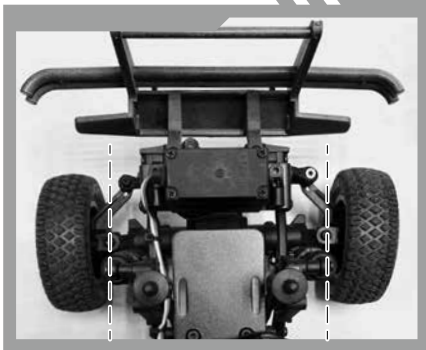

Return the steering wheel to neutral. The front tires/wheels should point straight forward. If not, use the steering trim lever to correct it.

方向回中立點時，前輪應筆直向前，若有偏差，請調整方向微調旋鈕。

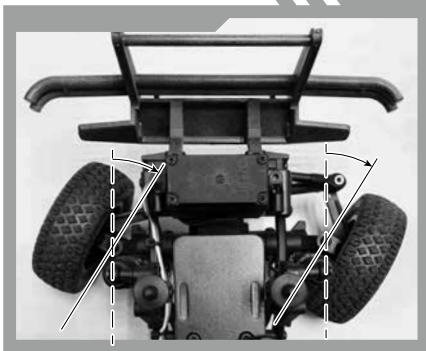

Turn the steering wheel to the right. The front tires/ wheels should turn right accordingly.

方向轉向右邊時，前輪應轉向右邊。



DRIVING BASIC 操控基本動作



Stop (Neutral)
停 (中立點)

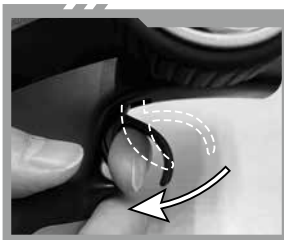

Acceleration
加速

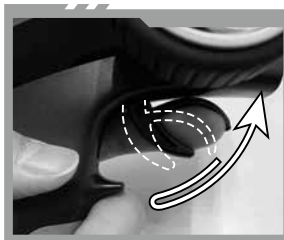

Brake
煞車

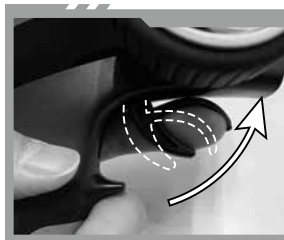

Reverse
後退



PART#	DESCRIPTION 品名	PART#	DESCRIPTION 品名
PG-21000	BALL BEARING 10X15X4 >>> 軸承 10X15X4	PG-21016	SHOCK SPRING >>> 避震器彈簧
PG-21001	BALL BEARING 5X10X4 >>> 軸承 5X10X4	PG-21017	SHOCK SHAFT SET (4PCS) >>> 避震軸心組
PG-21002	CVD JOINT / SPRING / PIN >>> CVD 連接座組	PG-21018	SHOCK PISTONS (4PCS) >>> 臂震器活塞
PG-21003	SPUR GEAR SHAFT PIN >>> 中差齒固定軸 PIN 2X7.8	PG-21019	BUSHING / O-RING SET >>> 避震器下蓋護套 / O 型環
PG-21004	WHEEL NUT PIN >>> 輪胎轉接座 PIN	PG-21020	SHOCK BODY SET, PLASTIC (4PCS) >>> 避震器配件
PG-21005	BODY CLIPS >>> 車殼插銷	PG-21021	SHOCK BALL END SET (4PCS) >>> 避震器下拉桿頭
PG-21006	BALL STUD 5.0 LONG >>> 球頭 5.0 長	PG-21022	SHOCK SET (2PCS) >>> 避震器組
PG-21007	BALL STUD 5.0 SHORT >>> 球頭 5.0 短	PG-21023	DIFF BEVEL GEAR 39T >>> 大齒輪 39T
PG-21008	DRIVE SHAFT JOINT >>> 傳動軸連接座	PG-21024	PINION GEAR 16T >>> 小齒輪 16T
PG-21009	SCREW SHAFT-L/S (4PCS) >>> 螺絲插銷 長 / 短	PG-21025	CENTER DRIVE CUP SHAFT >>> 中央接杯固定軸
PG-21010	CENTER DRIVE SHAFT >>> 中央傳動軸	PG-21026	GEAR DIFF CASE >>> 差速殼
PG-21011	FRONT DRIVE SHAFT >>> 前傳動軸	PG-21027	DIFFERENTIAL SET >>> 差速組
PG-21012	FRONT CVD DRIVE CUP >>> 前 CVD 接杯	PG-21028	CENTER SPUR GEAR 56T >>> 中差齒 56T
PG-21013	FRONT CVD SET >>> 前 CVD 組	PG-21029	MOTOR GEAR 15T SET >>> 15T 馬達齒組
PG-21014	REAR WHEEL AXLE >>> 後輪軸	PG-21030	BUMPER & BODY POSTS PART >>> 防撞板架 / 車殼支柱配件
PG-21015	CENTER SHAFT >>> 中差軸	PG-21031	WHEEL HEX (12mm) >>> 輪胎轉接座 (12mm)



PART#	DESCRIPTION 品名
PG-21032	STEERING BLOCK >>> 前輪座
PG-21033	C-HUB SCREW 3x11.6 >>> C 座螺絲 3x11.6 半牙
PG-21035	BATTERY STRAPS (2PCS) >>> 電池魔鬼氈
PG-21036	LION 850mAh BATTERY >>> 850mAh 鋰鐵電池 T 插
PG-21037	BRUSHED WATERPROOF ESC >>> 防水電子變速器
PG-21038	3.5KG SERVO >>> 3.5kg 伺服機
PG-21039	2.4G RADIO >>> TF-3 2.4G 遙控器組
PG-21040	CENTER DIFF MOUNT >>> 中差固定座
PG-21041	CENTER DIFF GEAR >>> 中差減速齒
PG-21042	BEARING 3x6x2.5 >>> 軸承 3x6x2.5
PG-21043	ADJUSTABLE LINK STEERING 41MM >>> 伺服機拉桿
PG-21044	SERVO SAVER >>> 伺服保護組
PG-21045	380 BRUSHED MOTOR >>> 380 有刷馬達
PG-21046	WHEEL SET (2PCS) >>> 像真輪框組
PG-21047	TIRE SET (2PCS) >>> 像真胎皮組
PG-21048	PRE-GLUED TIRE SET (2PCS) >>> 輪胎組

PART#	DESCRIPTION 品名
PG-21049	AXLE HOUSING SET-FRONT (2PCS) >>> 齒輪箱組 (前)
PG-21050	ADJUSTABLE LINK SET-FRONT (2SET) >>> 金屬拉桿組 (前)
PG-21051	4x4 AMERICAN PICKUP BODY SET >>> PUBG PICKUP 車殼組
PG-21052	BUMPER SET (F/R) >>> 防撞板組
PG-21053	BATTERY HOLDER PLATE SET >>> 電池固定板組
PG-21054	BODY POST (4PCS) >>> 車殼支柱
PG-21055	AXLE HOUSING SET -REAR (2PCS) >>> 齒輪箱組 (後)
PG-21056	ADJUSTABLE LINK SET-REAR (2SET) >>> 金屬拉桿組 (後)
PG-21057	SHOCK CAP BUSHING >>> 避震器上蓋襯套
PG-21058	M4 LOCK NUT >>> M4 尼帽
PG-21059	USB CHARGER 7.4V(OP500mAh) >>> USB 充電線 7.4V(輸出 500mAh)
PG-21060	C-CHANNEL FRAME (L/R) >>> C 型車架

PART#	DESCRIPTION 品名	OPTION
PG-30001	4x4 AMERICAN PICKUP 8PCS LED LIGHT SET (FRONT) >>> PUBG PICKUP 前 LED 燈組	
PG-30002	4x4 AMERICAN PICKUP 4PCS LED LIGHT SET (REAR) >>> PUBG PICKUP 後 LED 燈組	
PG-30003	ALUMINUM CNC SHOCK SET 4PCS >>> PUBG 鋁合金避震筒身組 (4PCS)	



4X4 AMERICAN PICKUP TRUCK

#20000